

## Tracking The Blade

1. Your blade should track the same on the drive wheel as it does on the idler wheel. To adjust the tracking on the blade, first slightly loosen the bolts that hold the band wheel pillow block bearing down.
2. If the blade needs to be set back, loosen the lock nuts and adjust band wheel bearing push bolts so that the band wheels are tipped outward.
3. If the blade needs to be brought forward, adjust its band wheel bearing push bolts so that the band wheels are tipped inward.
4. Tighten the bolts that hold the pillow block bearing down.

Note: All tracking adjustments should be made with the blade on at full tension. Rotating the band wheels by hand and visually inspecting the blade tracking will help to ensure that the proper adjustments were made.

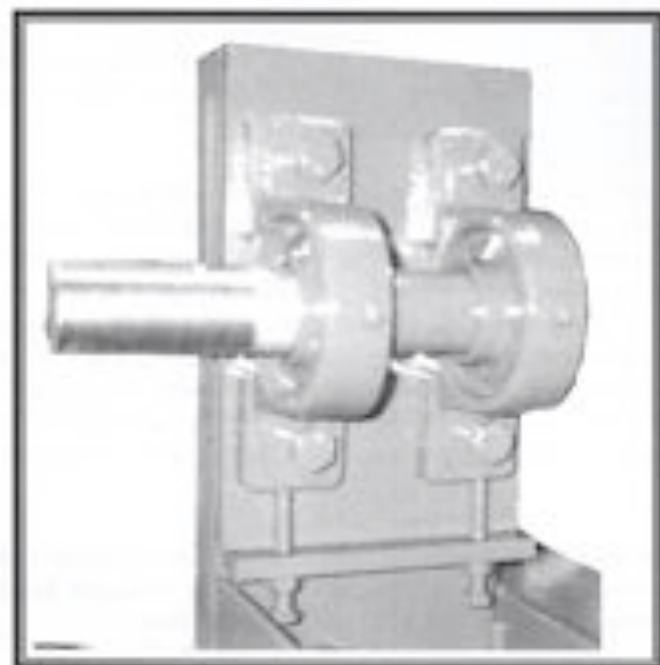

Figure E

## Changing The V-Belts

### IDLER WHEEL

1. Remove the blade as instructed on page 9.
2. Remove the old idler V-Belt from around the idler wheel.
3. Put the new belt on the idler wheel.
4. Put the old blade back on or replace it with a new one.

### DRIVE WHEEL

1. Remove the blade as instructed on page 9.
2. Loosen the bolts that hold the engine to the motor mount plate.
3. Slide the engine toward the drive wheel.
4. Remove the old V-Belt.
5. Put the new belt on over the Drive Wheel and the engine pulley.
6. Tighten the drive belt by sliding the engine away from the drive wheel.
7. Tighten the bolts that hold the engine to the motor mount plate.

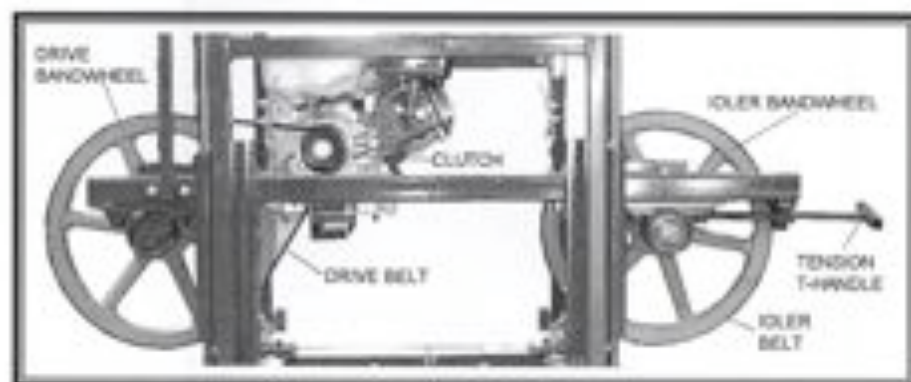

Figure F

## Setting The Guides

1. Attach the top guide plate to the guide depth bracket with the four bolts.
2. Mount the assembled guide depth bracket to the guide height bracket, and hand tighten the guide height bracket bolt and the guide depth bracket bolt.
3. Set the top guide plate on the blade until it barely touches, ensuring that it is even across the blade. You do not want the blade to drag on the guide.
4. Once the top guide plate is in the correct position, tighten the bolts with a wrench.
5. Remove the four bolts connecting the guide depth bracket and top guide plate.
6. Place the spacer then the bottom guide plate under the top guide plate.
7. Replace the four bolts to attach the bottom guide plate, spacer and top guide plate to the guide bracket.

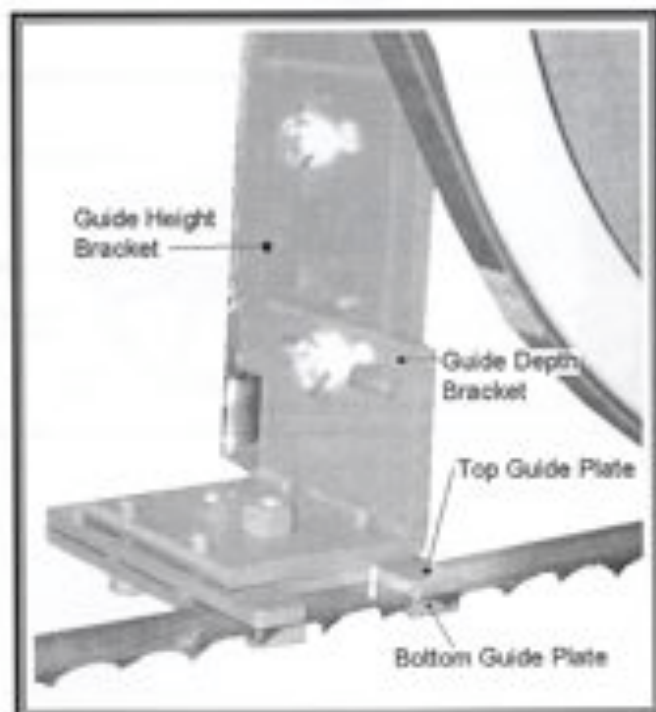

Figure G

## Blades

Your mill requires a 11'-2" x .035 x 1-1/4" blade if it is equipped with 16" wheels and 11'-8" long on 18" wheels. For best results, we recommend Lenox Wood master C Band Blades. Baker Products is an authorized distributor of Lenox Band Blades, contact our parts department for more information. Canada 800-387-5553 or U.S.A. 573-663-7711.

Ensure all safety precautions are followed whenever any maintenance or repair is performed on your sawmill.

**REMOVE:** Remove the guards. Release the tension from the blade by turning the tension T-handle counter clockwise (figure D.) When the blade is loose enough, (wearing gloves) pull it off the wheels and out of the guides.

**REPLACE:** Put the new blade over the wheels and through the guides with the teeth facing forward and pointing to the dust shoot. Ensure the blade gullet is 1/32 out from the face of the wheels. This is to avoid knocking the set out of the blades. Turn the tension T-handle clockwise until the blade is fully tensioned. The blade should be tight enough so there is minimal deflection when you push downward on it between the guides with two fingers. Manually rotate the wheels to ensure the new blade is tracking properly. Replace the guards and make sure they are securely locked.

**LUBRICATE:** The type of lubricant used on the blade depends a great deal on the species of wood being cut. Hardwoods (oak, hickory, walnut, cherry, maple, etc) do not contain high amounts of pitch. In this case, water will be an adequate lubricant to use. Softwoods (pine, hemlock, spruce, etc) contain high amounts of pitch. Excessive amounts of pitch can stick to the blade and the blade guides causing friction. This will lead to rapid heat build up and cause blade breakage. To prevent this, use a high quality dishwashing liquid mixed well with water. For extreme build up on the blades, a water soluble oil can be used. Apply the lubricant with a spray bottle in between cuts. Some species of wood may require some lubrication in the cut.

**WARNING:** Diesel fuel or any other flammable liquids should not be used as a lubricant. Baker Products will not be held responsible for any damage if this caution is not adhered to. Diesel fuel will attack and damage rubber items.

## Overall View



Figure B  
Shown is the log clamp and fence post used to clamp the logs before they are sawn.

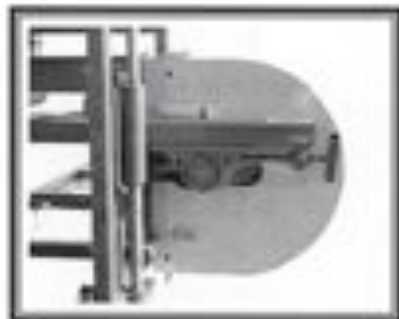

Figure C  
The tension T-handle is cranked clockwise to increase the tension on the band.



Figure D  
Your track should be set up on either a level, firm surface or on a level surface with boards under the length of the mill on both sides.

## Making The Cut

After you have read and understand this manual, and have familiarized yourself with the layout and operation of the mill, you are ready to cut wood. Ensure all setup procedures have been followed and that all safety precautions are observed. Verify that all personnel working in the vicinity of the mill understand all safety precautions and that all personnel have and are correctly using appropriate safety equipment.

1. Move the head to the front of the mill. Use a cant hook to roll a log onto the track.
2. Raise the log clamp and fence post just over half the height of the log's diameter. Screw in the clamp so that the log is held firmly against each of the fence posts.
3. Push the head up close to the end of the log, adjust the head to the desired height of the first cut. Adjustments are made by turning the crank handle (figure C, page 8). Check the lumber scale to see what measurement you will be starting at. You may want to move to one of the markings (4/4, 5/4, 6/4, 8/4) to make it easier to get your desired board thickness. Note: the lumber scale is flipped down for shipping of the mill.
4. Start the engine and allow it to warm up. Bring the engine to full R.P.M. To engage the centrifugal clutch that engages the blade.
5. Enter the wood slowly, then gradually increase the head speed. If the engine starts to bog down, slow the head speed. Cutting speed will vary according to the hardness of the wood and the width of the material being cut. When you get through the log, raise the head slightly, remove the board or slab that you just cut, and then return the head to the front of the track.
6. Adjust the blade height to the next marking (4/4, 5/4, 6/4, 8/4,) and cut your next board.
7. Continue the process, rotating the log as needed, until finished.

**Warning:** Changing head direction before the blade is clear of the material will result in the blade being dragged out of the guides and off the wheels. This can result in personal injury and/or equipment damage.

## Use Of Lumber Scale

All models are equipped with a lumber scale which simplifies the lumber dimensioning process. The scale incorporates four separate scales with the blade kerf allowed for in each increment.

4/4 Scale	1" Thick Boards
5/4	1-1/4" Thick Boards
6/4	1-1/2" Thick Boards
8/4	2" Thick Boards

Note: The left hand scale, starting at (1) one and going to (18) eighteen does not compensate for the kerf of the blade. If you were to cut on these marks you would get boards that are about 1/8" thinner than the distance you dropped. So if you were to make a cut on the 6" mark and then the 5" mark, you would get a board just over 7/8" thick. This scale is very useful for sizing the width of boards and the size of cants.



## Important: Read this before operating your Baker Band Sawmill

Turn off power, lock out, and tag out before making any adjustments to the mill.

Some screws may become loosened during transport. Remove all guards and check to see that all set screws on mill are tight before operating and again after the first week.

Check set screws monthly.

Do not fill fuel tank while engine is running.

Always wear proper eye and ear protection when operating the mill.

Never wear loose clothing when operating the mill.

Before starting, make sure that the blade teeth are traveling from right to left while standing in front of cowling door toward sawdust discharge chute.

Never open cowling door while the mill is running.

Stay away from blade when operating the mill.

Make sure that the mill is properly blocked and leveled.

Check to see if the blade drive "V" belts are worn.

A visual inspection of the mill each day prior to starting is recommended.

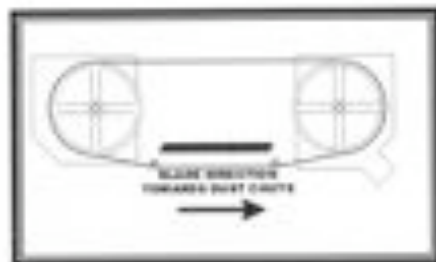

Figure A

## *Service policy*

In the event that you have any problems, call us at (800) 387-5553 any time between 8:00 AM and 5:00 PM (EST), Monday to Friday. A member of our trained staff will answer any questions you may have. We charge nothing for this service.

The only charge is for replacement parts not covered by warranty or after our inspection we deem that the problem is due to operator error or lack of proper maintenance.

## *Setting Up The Track*

Every Wood Buddy Sawmill comes with at least 3 sections of track. The three sections are identical. The track should be set up in a fairly level place on firm ground. Bolt the three sections of track together. Make sure that the track is fairly level and straight from one end to the other. Put a level on the bunks to make sure that they are equally level.

Bolt the end stops to each end of the track.

Install the fence post and the log clamps in the appropriate position for the length of logs you will be sawing.

You are now ready to put the carriage on the track. Make sure that the carriage is put on so that you will saw from the front to the back.

Additional sections of track can be purchased and added to your track.

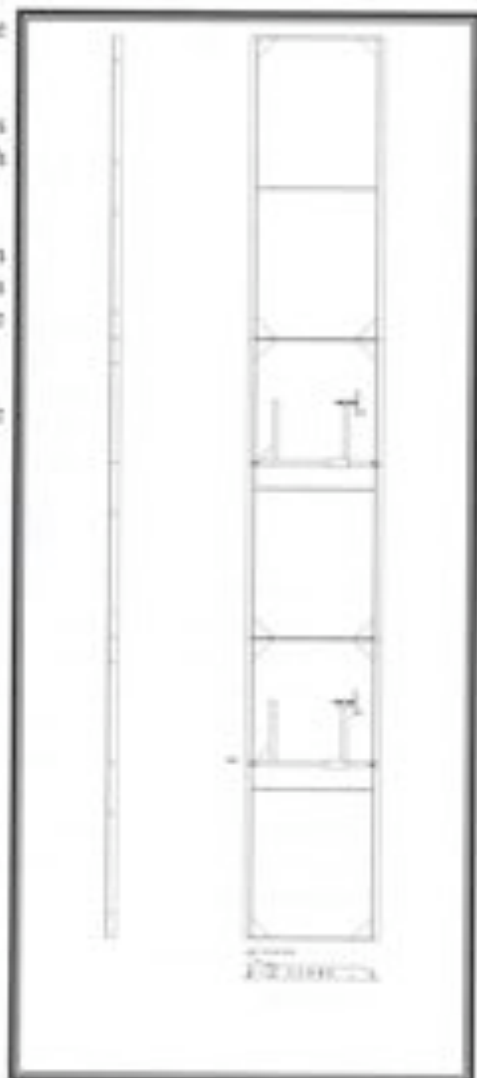



## Max-Torque, LTD

*The Name that defines clutches- since 1957*

2180 Corporate Lane  
Suite #116  
Naperville, IL 60563  
Phone # 630-389-0600  
Fax # 630-389-0686

[info@maxtorque.com](mailto:info@maxtorque.com)

### **Pulley Clutch**

Max-Torque pulley clutches utilize the same proven sintered metal shoes, garter spring and oil impregnated bronzed bushing as the "SS" clutch. Our standard pulley clutch has a 3.20" OD pulley that will accommodate either an A or B belt. Pulley diameters can be made to meet your requirements.

**Maintenance:** Squirt four (4) drops of 30 weight oil on clutch bushing just behind the snap ring area by the sprocket (or puley). Make sure the bolt and washer are tight.

OIL BUSHING EVERY TWO (2) HOURS TO MAXIMIZE BUSHING EFFICIENCY.

### **Warranty**

Enercraft/Baker Products Inc. has a company policy of continous improvement and development, therefore specifications are subject to change without notice or obligation. The company accepts no responsibility for discrepancies in specifications or illustrations contained in its publications, promotional literature, or advertisements.

#### **Engines and Motors**

Warranty is by the specific manufacturer and only their terms and conditions will constitute warranty. (See Owners Manual) All warranty work on above components is done by the closest dealer for these components, NOT Enercraft/Baker.

#### **Drive Bearings**

90 days from date of purchase

#### **Centrifugal Clutch**

90 days from date of purchase.

Note: V-Belts, blades and blade guides are not covered under warranty.

Weldments- One year, based on inspection, at our plant, Hillsdale, On.

The manufacturers responsibility under this warranty is limited to the repair or replacement (our option) of the defective part or parts, F.O.B., Hillsdale, Ontario. It is the responsibility of the Original Owner, to return to Enercraft/Baker, Hillsdale, Ontario, Freight Prepaid, all parts for inspection. Enercraft/Baker will not be liable for a special, indirect, incidental, or consequential damage of any kind whatsoever. To avoid loss of warranty, do not dismantle or repair any components until first having approval from Enercraft/Baker.

The manufacturer and their authorized representative reserves the right to determine whether the parts have failed because of defective material and workmanship or caused by misuse, abuse, improper operation or unauthorized warranty service or parts.

All warranty repairs must be done by the manufacturer or their authorized representative, unless approved by Enercraft/Baker, in writing, prior to the commencement of any work.

All other work done will VOID WARRANTY.

This warranty is in lieu of all other warranties, expressed or implied including warranties of merchantability and fitness for a particular purpose.

## ***Introduction***

Congratulations on the purchase of your new Baker Band Sawmill. It should provide you with many years of profitable operation.

Your Baker Band Sawmill has been designed to be sturdy, simple, and easy to use by one person.

For safety reasons, and for your own best use of the mill, we do insist that you read and follow this manual fully, and constantly review/refer back to it. Note that this manual may contain details that if not properly followed can affect the performance of your mill and we reserve the right to deny warranty work if deemed to be caused by lack of proper maintenance.

We hope this Manual will familiarize you enough with the mill so that you will be able to easily make any adjustments that may ever become necessary.

If you have any questions or comments, please feel free to contact us

Enercraft/Baker Products Inc.  
2365 Cassell Drive,  
Hillsdale, Ontario, L0L 1V0  
800-387-5553  
Fax: (705) 835-2788

OR

World Wide Equipment Sales, Inc.  
PO Box 128  
Ellington, Missouri, 63638, U.S.A.  
(573) 663-3133  
Fax: (573) 663-2787

## ***Recommended Spare Parts List***

SH-BSB44	11'-2" X .035 X 1-1/4 X 1.1T Lenox Band Blade For 16" hand wheels
SH-BSB45	11'-8" X .035 X 1-1/4 X 1.1T Lenox Band Blade For 18" hand wheels
141149	Guide Plate
SH-RGB	Guide Bearing

Parts and service may be obtained by contacting Enercraft/Baker Products Inc. Or Ellington Industrial Supply Inc.

Enercraft/Baker Products Inc.  
2365 Cassell Dr.  
Hillsdale, ON, L0L 1T0  
Ph 800-387-5553  
Fax 705-835-2788  
canada@baker-online.com  
www.baker-online.com

Ellington Industrial Supply Inc.  
Po Box 128  
Ellington, MO, 63638 USA  
Ph 573-663-3133  
Fax 573-663-2787  
info@baker-online.com  
www.baker-online.com

## *CONTENTS*

Introduction	4
Warranty	5
Service Policy	6
Important: Read before operating mill	7
Overall View	8
Blades	9
Tracking The Blade	10
Changing The V-Belts	11
Setting The Guides	12
Making The Cut	13
Use of Lumber Scale	14
Setting Up The Track	15
Max-Torque Ltd. Clutch Maintenance	16
Recommended Spare Parts List	17





# **BAKER PRODUCTS**

**SAWMILL DIVISION**

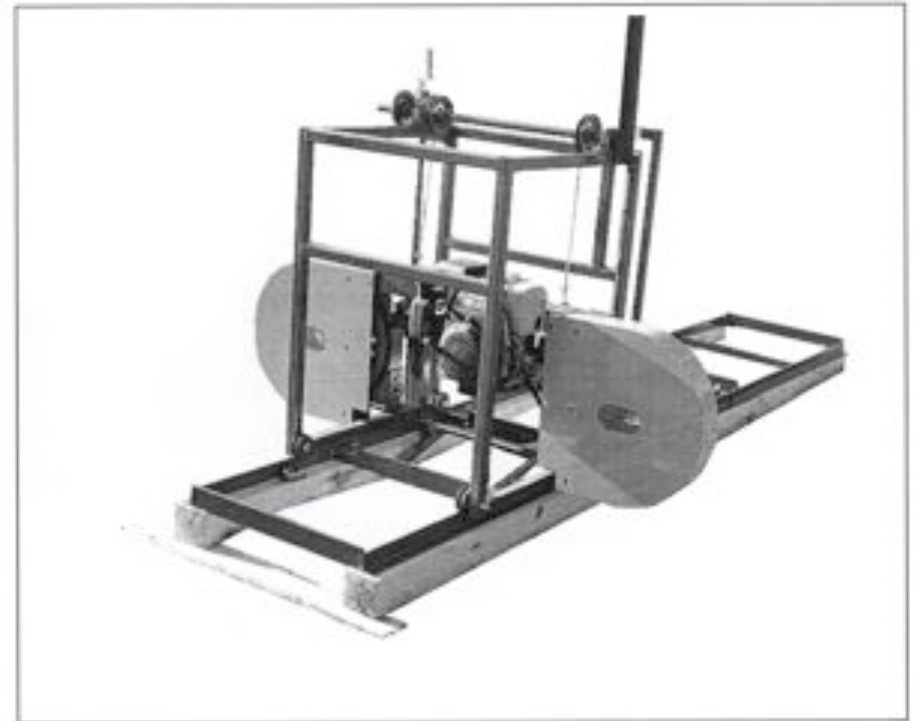

## WOOD BUDDY OWNERS MANUAL